

For information about other American International automotive accessories visit our website at:

<http://www.aius.net>

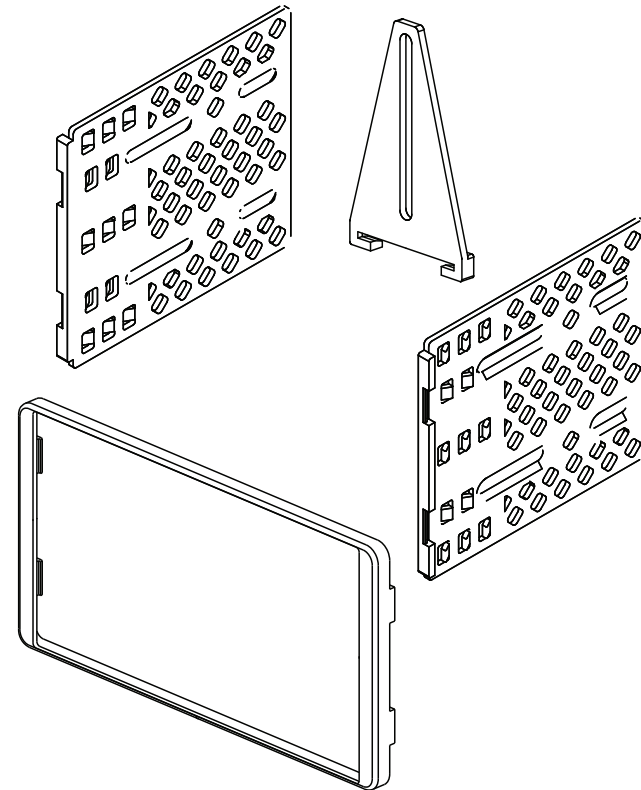

American International
Car Stereo Installation Kits & Accessories



FMK552 Mounting Kit



American International

WWW.AIUS.NET

2500 East Francis Street Ontario, CA 91761, U.S.A.

USA Sales (800) 336-6500

Canada Sales (888) 922-3006

CUSTOMER HELP LINE

USA 800-323-4329 • Canada 800-245-8777

iFMK552

VEHICLE APPLICATIONS

FORD

1997-2008 Club Wagon
1997-2008 Econoline Van
2001-2007 Escape
2000-2006 Excursion
1995-2001 Explorer (all models)
1999-2003 F-Series trucks
2004 F-150 (Heritage model only)
1995-2011 Ranger
1999-2003 Windstar

LINCOLN

*1995-1997 Continental
*1996-1998 Mark VIII
*1998-2002 Town Car
* See special note section on next page.

MAZDA

1995-2011 B-series Pick-up's

MERCURY

2001-2002 Cougar
2006 Mariner
1997-2001 Mountaineer

***Note:** Majority of installations of a double DIN radio with the FMK552 will require minor to major dash and subdash modifications.

FACTORY RADIO REMOVAL

For ease of factory radio removal, use American International radio removal tool set **part# URT-460** (sold separately).

SPECIAL NOTES

CAUTION: This installation kit is designed to go into the vehicles listed. Once the kit is installed into the dash opening, if you need to remove the aftermarket radio, you will have to remove the dash trim bezel to do so. The vehicles listed in the vehicle application section of this instruction sheet that have an (*) asterisk next to them require that the vehicles entire dash be removed to be able to get the installation kit and after market radio components out without damaging the vehicles dash integrity.

Liability Disclaimer

NOTE: American International assumes no fault or liability of damages for any part of the vehicle or radio components on installation or removal of the FMK-552 into these vehicles.

KIT ASSEMBLY INSTRUCTIONS

1. Using screws provided with radio components attach left and right side brackets to the (2) ISO mount components (do not tighten at this time).
2. Attach ISO trim ring to ISO mount brackets.
3. Adjust radio components forward or backward for desired look and tighten mounting screws when desired look is attained.
4. Remove trim ring from ISO mount assembly.

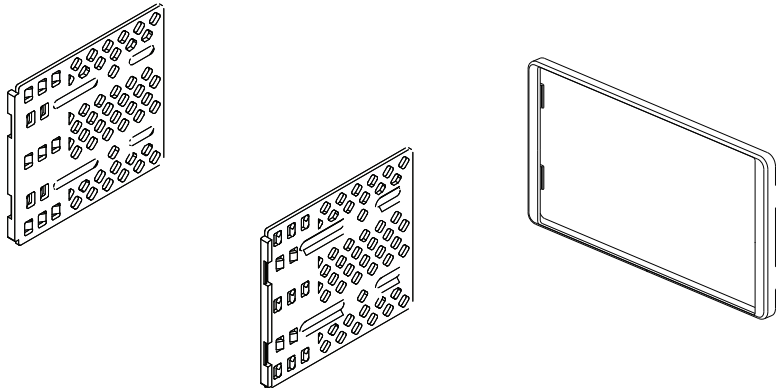

RADIO INSTALLATION INSTRUCTIONS

NOTE: The installation for this kit requires dash modification.

1. Carefully remove the top and bottom lip sections from the inside of the dash bezel's radio opening.
2. Attach rear support bracket to the rear of the ISO mount radios. (Support bracket may be located on top or bottom depending on vehicle)
3. **CAUTION: See Special Notes section on page 2**
4. Insert radio assembly into dash opening and lock into place.

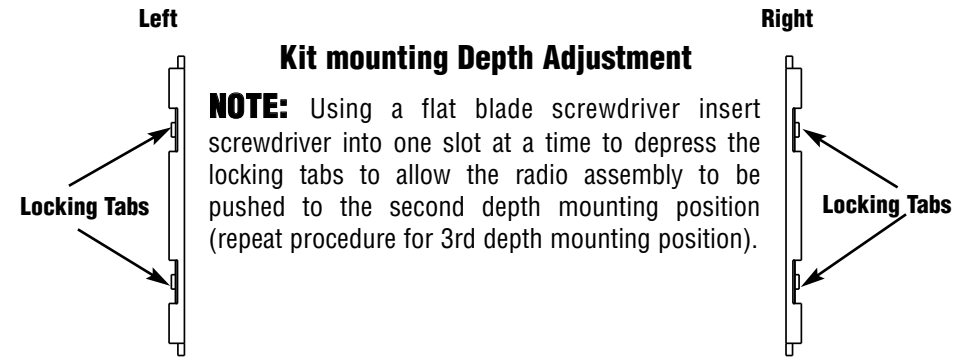

5. Attach installation kit trim ring only after desired mounting depth has been achieved.

Double DIN Trim

