

SWEDISH • AUDIO • PASSION





ACW10I

User manual

10" Active Slim Subwoofer

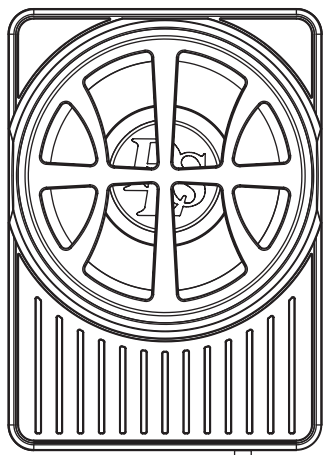

REFERENCE



Welcome to DLS!

Thank you for buying a DLS Reference ACW101 active slim subwoofer. For us, it's all about the sound experience. We care deeply about sound and construction quality. In order for your experience to be as optimal as possible, it is important that you fully read this manual, preferably before you start your installation. Keep the manual in a safe and accessible place for future reference.

Your subwoofer must be installed correctly in order to work as intended. Make sure you have all necessary tools nearby before starting and that you are completely confident in how to process. If you feel the slightest uncertainty; feel free to take the help of an experienced installer or a car audio dealer.

Warranty

This subwoofer is covered by warranty, depending on the conditions in the country where it is sold. If the speaker is returned for service, please include the original dated receipt with the product.

DECLARATION OF CONFORMITY

DLS subwoofers for vehicles are manufactured in accordance with the EU directive EEC 95/54 (72/245/ EEC) and are marked with the approval number. They are also marked in accordance with the WEEE-directive 2012/19/EC. The products are also produced in accordance with the EU RoHS directive 2015/863/EU.

DLS REFERENCE *ACW101*

Content

| | |
|-------------------------|----|
| Features | 2 |
| Installation | 6 |
| Troubleshooting testing | 8 |
| Professional tips | 9 |
| Specifications | 10 |
| Dimensions | 11 |
| Product markings | 12 |

DLS speakers are engineered by DLS Sweden,
a part of:

Winn Scandinavia AB

Idrottsvägen 37 - SE-702 32 Örebro - Sweden

Tel: +46 19 20 67 65 - E-mail: info@dls.se

www.dls.se

Designed & Sound tuned in Sweden.

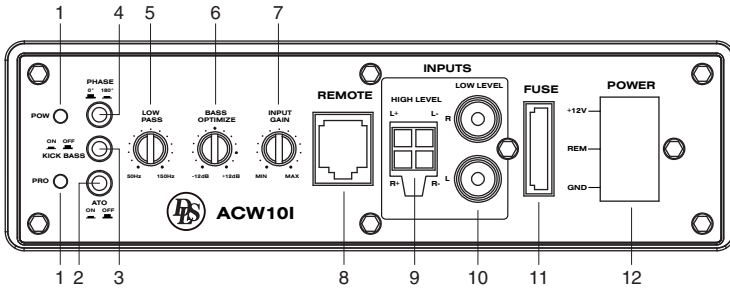

Features

1. Power & Protect Status LEDs

PWR (Power) LED glows green when power is turned on and no problems are present.

PRO (Protect) LED glows red if one of the protection circuits comes on.

2. Auto Turn On

The auto power on (ON/OFF) is for high level (speaker-level) connections. When the switch is in the "ON" position, the subwoofer auto power on when there is signal input. If the amplifier detect no signal input, the amplifier will auto turn off. If you prefer to use the remote turn on/off connection, set the switch in the off position.

Note: Please connect the remote terminal to the remote output of head unit as Fig.4. When you turn on/off the head unit a receipt pulse can be heard from the subwoofer.

3. Kick Bass Subsonic Filter

The ACW101 is possible to use as a high power active midbass enclosure. Placed under the front seat/seats, kickpanel/kick-panels or under the glove compartment it provides a great improvement in the normally difficult 60-100Hz midbass region. In combination with a larger second subwoofer, normally placed in the trunk, you can achieve a complete high impact and quality subwoofer solution in the 20-100Hz range.

Use "OFF" setting for stand alone configuration (no extra subwoofer).

Use "ON" setting for kick bass option.

4. Phase Shift

Use this switch to help compensate for time alignment problems in the system. Such problems usually result from having the subwoofer at a different distance from the listener than the other speakers in the system.

5. Low Pass Filter

This control permits you define the frequency range you want the subwoofer amplifier to receive. The subwoofer will reproduce all sound BELOW the frequency you set.

Note: The low pass filter frequency can be higher or lower than the visual scale.

6. Bass Optimize

The Unique DLS Bass Optimize control features a carefully Q-matched -12dB/+12dB range @45Hz range to perfectly tune the bass response when connecting to OEM factory radio. The fixed bass boost in factory radios deteriorate bass musicality from additional subwoofers because of the 40-60Hz bump in factory radio output. With DLS Bass optimize control you can tune the low bass in your car to an unrivalled natural bass.

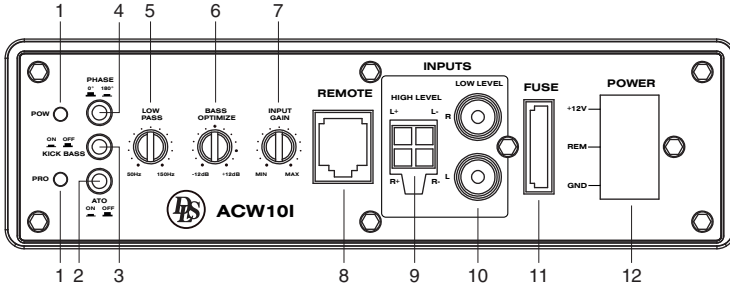

Features

7. Input Gain Control

After you have installed your system, turn this control to minimum. Turn the head unit on (and the subwoofer will turn on via the remote connection). Turn the head unit volume to about 2/3 full level. Slowly turn up the subwoofer input gain control until you hear a small amount of distortion. Then reduce the level until the distortion is completely gone. Leave the control at this setting.

8. Remote Level Control Port

Attach the included remote level control to control the volume level of the subwoofer from the dashboard.

9. High Level input

If your head unit does not have RCA outputs you can use the speaker outputs for the audio source for the subwoofer. Use the supplied cable and wire harness and connect the outputs properly as shown in the connection diagram.

The HLI features DLS proprietary Smart Load Circuit, SLC. SLC is required for an error free function in newer cars with advanced OEM diagnostics sound systems. The SLC provides an easy and hassle free installation for your ACW101.

10. Low Level input

Low level inputs are the recommended way to input the audio signal to the subwoofer if RCA outputs are present on your head unit or other signal source (such as a sound processor).

11. Fuse

12. Power Input Terminal

Simplified connection with the supplied releaseable power connector.



NOTE: Do not connect BOTH the high level and low level inputs from your receiver to your amplifier at the same time.

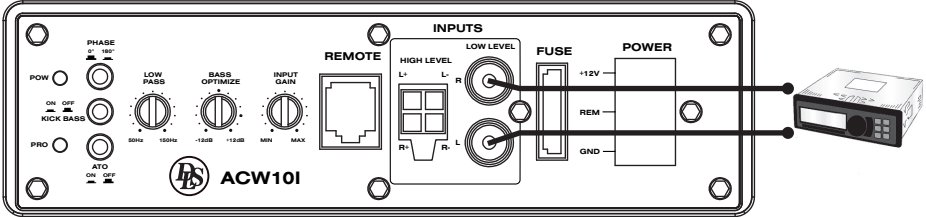

Low Level Input Wiring

Low-level (RCA) input wiring is preferred for best audio performance. Most trunk or hatchback installations will require a 15-20 feet RCA cable, while pickup trucks and under seat installations will require a 6-12 feet RCA cable. Always use a high quality cable.

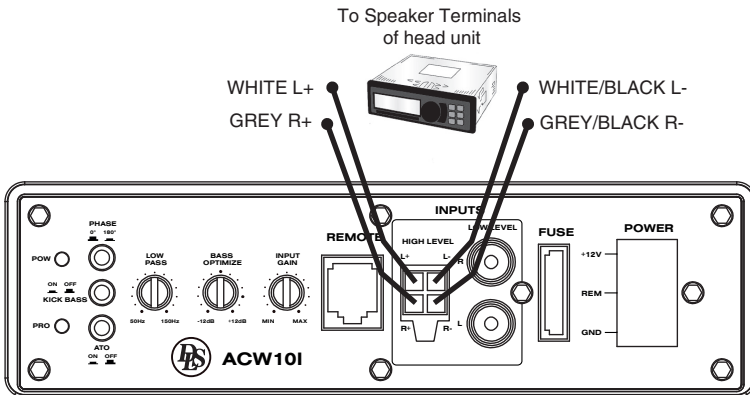

High Level Input Wiring

Most headunits are pre-installed from the car factory and have no RCA out-put, in this case you can use the signal from the speaker output. Connect left and right speaker wires coming from the car stereo to the high level input as shown. Be sure to observe polarity to avoid audio phase problems.



Power Terminal

Connect the fuse holder as close to the vehicle battery + as possible and connect the cable on the rear panel on the subwoofer. Use a ring crimp terminal connector to battery.

Remote Terminal

Connect the remote terminal to the remote output of the head unit. This turns on the amplifier whenever the car stereo is turned on.

Ground Terminal

Connect to a good chassis ground. The ground connection should be clean, unpainted metal to provide a good electrical connection. Use a wire brush, a scraper or a piece of an abrasive sheet to clean the metal.

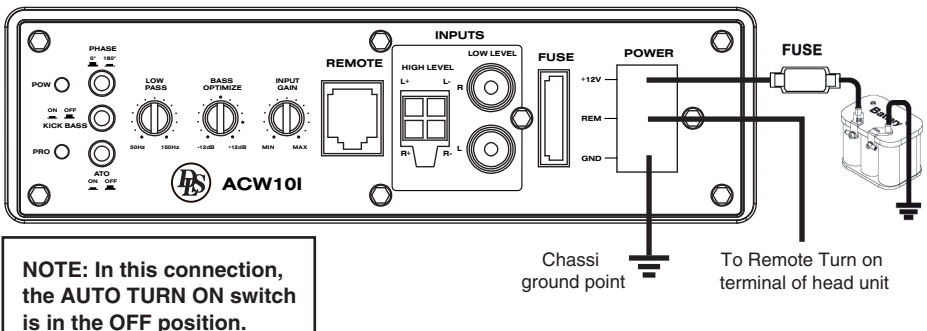
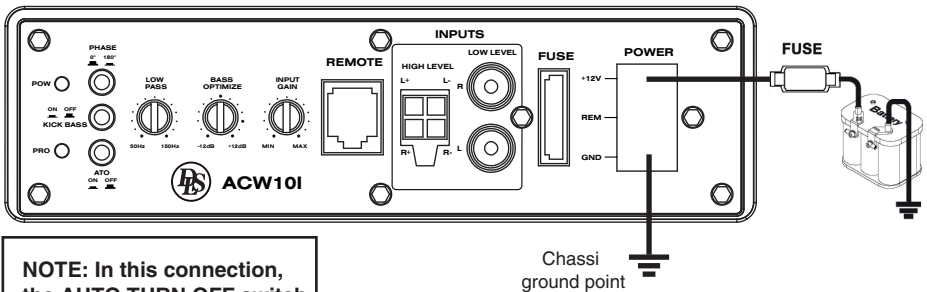



Installation

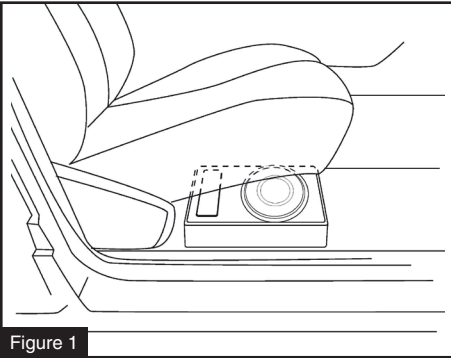

Figure 1

Under the seat

1. The seat must be positioned in its normal fixed position.
2. Decide the best location possible that suits your automobile and space available, checking that the enclosure doesn't restrict the seat mobility. (See Figure 1)
3. Ensure the area for subwoofer location is clean and tidy. Any loose objects must be removed.
4. Once the location has been decided, mark the screw hole positions for the fixing brackets.
5. Drill holes of 2 mm for the 4 fixing brackets, at your defined locations.
6. Fix the clamps to the subwoofer case with the four screws M4*6 (the fixing clamps have a mounting direction system) see (Figure 2 & 3)
7. Position the subwoofer so that the holes correspond to the metal supplied screws and fix it. (Figure 4)
8. Please make sure the subwoofer enclosure is tightly fixed.

We include a fixing kit to ensure the subwoofer remains securely mounted. Two types of installation are possible.

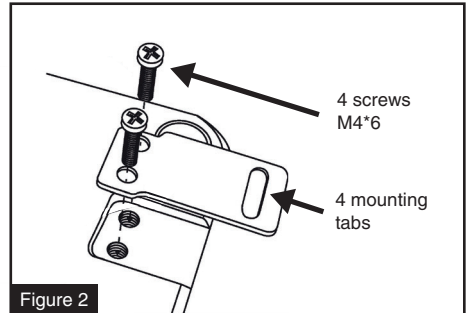

Figure 2

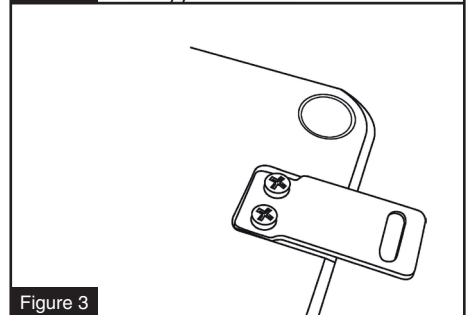

Figure 3

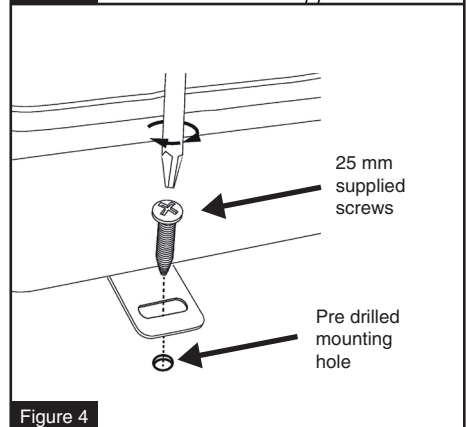

Figure 4



Installation

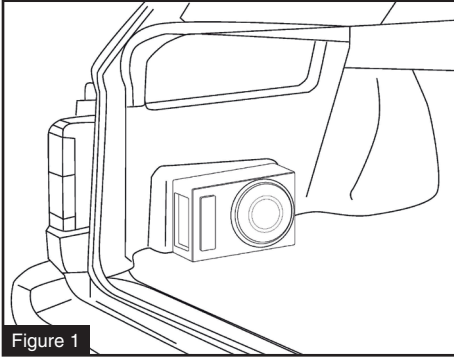

Figure 1

We include a fixing kit to ensure the subwoofer remains securely mounted. Two types of installation are possible.

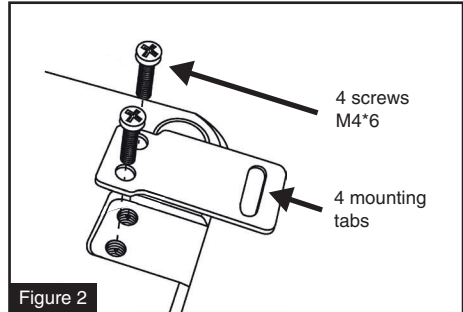

Figure 2

In the trunk

1. Rear seats must be positioned in their normal fixed position.
2. Decide the best location possible that suits your automobile and space available. The best and most secure location for optimum sound quality is behind the rear seats, in the trunk floor (see Figure 1).
3. Ensure the area for subwoofer location is clean and tidy. Any loose objects must be removed, as they could knock and damage the subwoofer.
4. Once the location has been decided, mark the screw hole positions for the fixing brackets.
5. Drill holes of 2 mm for the 4 fixing brackets, at your defined locations.
6. Fix the clamps to the subwoofer case with the four screws M4*6 (the fixing clamps have a mounting direction system) see (Figure 2 & 3)

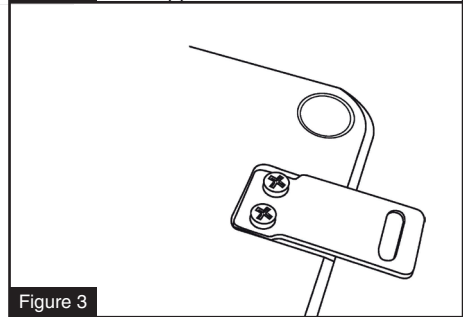

Figure 3

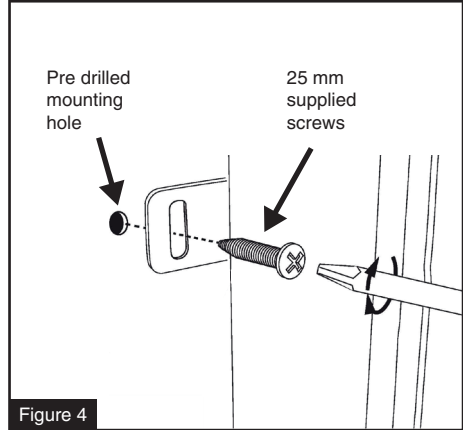

Figure 4



Troubleshooting testing

If you experience operation or performance problems with this product, compare your installation with the electrical wiring diagram on the previous pages. If problems persist, read the following troubleshooting tips which may help eliminate the problems.

| | |
|-------------------------------------------------------|--------------------------------------------------------------------------------------------------------------------------------------------------------------------------------------------------------------------------------------------------------------------------------------------------------------------------------------------------------------------------------------------------------------------------------------------------------|
| Amplifier will not power up. | <p>Check to make sure you have a good ground connection.</p> <p>Check that the Remote Input (Turn-On) has at least 5VDC.</p> <p>Check that there is battery power on the (+) terminal.</p> <p>Check that there is at least 12v.</p> <p>Check all fuse, replace if necessary.</p> <p>Make sure that the Protection LED is not illuminated. If it is lit, shut off the amplifier briefly, and then repower it.</p> |
| Protection LED comes on when amplifier is powered up. | <p>Check for short circuits on speaker leads.</p> <p>Turn down the volume control on the head unit to prevent overdriving. Remote speaker leads, and reset the amplifier. If the Protection LED still comes on, then the amplifier is faulty and needs servicing.</p> |
| No output. | <p>Check that all fuses are OK.</p> <p>Check that unit is properly grounded.</p> <p>Check that the Remote Input (Turn-On) has at least 5VDC.</p> <p>Check that the RCA audio cables are plugged in to the proper inputs.</p> <p>Check all speaker wiring.</p> |
| Low output. | <p>Reset the Level control.</p> <p>Check the crossover control settings.</p> |
| High hiss in the sound. | <p>Disconnect all RCA inputs to the power sub's control panel. If the hiss disappears, then plug in the component driving the amplifier and unplug its inputs. if the hiss disappears at this point, go on until the faulty noisy component is found. It is best to set the amplifier's input level control as low as possible. The best subjective signal-to-noise ratio is achieved in this manner. Try to set the head unit as high as possible</p> |
| Engine noise (static type). | <p>This is usually caused by poor quality RCA cables, which can pick up radiated noise. Use only the best quality cables, and route them away from power cables.</p> |
| Engine noise (alternator whine). | <p>Check that the RCA grounds are not shorted to the vehicle chassis Check that the head unit is properly grounded.</p> |
| Amplifier gets very hot. | <p>Check that there is good air circulation around the amp. In same applications, it may be necessary to add an external cooling fan.</p> |



Professional tips

NOISE PROBLEMS

WHINING NOISE VARYING WITH ENGINE REVOLUTIONS:

Do this:

1. Rewire the power supply (12 V) to source unit direct from battery.
2. Rewire ground wire from source unit to clean position on chassis.
3. Check all power connections to ensure that they are clean and tight.
4. Check quality of system ground connection.
5. Install a Power Cap capacitor. This can be helpful against most noise problems.

CONSTANT WHINING NOISE:

Do this:

1. Ensure that all equipment has a common ground point.
2. Check quality of earth strap connection from battery negative terminal to chassis.
3. Disconnect signal cables from amplifier to see if noise disappears. If so the leads are picking up noise. Test this by laying a new cable over the seats and reconnecting to the amplifier. If the noise does not return, re-route original cable away from source of interference. If noise remains regardless of cable position, try to use so called Quasi-balanced signal cables. DLS PRO-cables are Quasi-balanced.

INSTALLING IN TRUNK

When installing the amplifier in the trunk, run the power wires along the same path as the other vehicle wiring. Many cars have insulated channels for wiring. You will have to remove the door sill trim and the carpet.

SPEAKERS AND POWER WIRES

Do not run speaker and power wires next to each other. Power wires can generate a "siren" sound in the speakers. Run speaker and power wires on opposite sides of the car.



Specifications

| | |
|-----------------------------|------------------------------------------|
| Model: | ACW10I |
| Amp: | Class AB |
| Power: | 200W RMS / 450W MAX |
| THD: | < 0.4 % |
| SNR: | > 95dB |
| Frequency Response: | 30Hz- 150Hz |
| Input sensitivity HLI: | 0.9V - 35V |
| Input sensitivity RCA: | 300mV - 6V |
| Smart Load Circuit SLA: | Yes |
| Auto turn on ATO: | Yes |
| Bass Optimize Circuit: | Yes, -12dB to +12dB @ 45Hz |
| Low Pass Filter: | Yes, 50Hz-150Hz |
| Kick Bass Subsonic Filter: | Yes, selectable OFF / ON @ 40Hz 12dB |
| External Bass Control EBC : | Yes incl. detent center position |
| Quick Power Connector: | Yes |
| Fuse Rating: | 25A |
| Subwoofer Driver: | 10 inch, 2 Ohm |
| Dimensions (LxWxH): | 13.6"/345 x 9.6"/245 x 3.1"/79 (inch/mm) |



Product markings



The crossed-out wheellie bin symbol means that the product, literature and packaging included must be taken to separate collection at the end of their working life. Do not dispose of these products as unsorted municipal waste: take them for recycling. For info on your nearest recycling point, check with your local waste authority.



This product has been granted with the CE certification mark to show that the product follows the health, safety, and environmental protection standards for products sold within the European Economic Area (EEA).



DLS products complies with the relevant provisions of the RoHS Directive for the European Union. In common with all Electrical and Electronic Equipment (EEE) the product should not be disposed of as household waste. Alternative arrangements may apply in other jurisdictions.



DLS is a global partner of the European Mobile Media Association, an organisation that focus on promoting the custom made mobile media installations to consumers.

We follow a policy of continuous advancement in development. For this reason all or part of specifications & designs may be changed without prior notice. We reserve for possible typos, factual or numeric errors that may have been printed on any products, package designs, user manuals and/or other included accessories.



REFERENCE