



CT23MB28

Double DIN Fitting Kit for Mercedes Benz Vehicles



APPLICATION

Note: Application data is subject to change at any time

Mercedes Benz	A Class (C169, 2 Door)	2004 - 2010
Mercedes Benz	A Class (W169, 4/5 Door)	2004 - 2012
Mercedes Benz	B Class (T245)	2005 - 2011
Mercedes Benz	Vito (W447)	2014>

RECOMMENDED TOOLS

- Panel Removal Tool
- Screwdriver

FEATURES

- Allows for the installation of a double DIN aftermarket stereo
- Includes mounting brackets and fitting accessories
- Finished in black to match vehicle dashboard

DISCLAIMER

The information provided in this document is subject to change without notice due to manufacturer changes and/or improvements to the product/s. This instruction manual is based on documented data and research. The manufacturer of this product cannot be held responsible for any changes made to the vehicle by the manufacturer or damages that may occur through the installation of this product in accordance with the steps outlined herein.

PRIOR TO INSTALLATION

Read the manual prior to installation. Technical knowledge is necessary for installation. The place of installation must be free of moisture and away from heat sources. Please ensure that the correct tools are using during the installation to avoid damage to the vehicle or product. Connects2 can not be held responsible for the installation of this product.

INSTALLATION GUIDE

1. Use a pair of hooks and insert them into the locations shown at the top corner of the air vents (Fig. 1)



Fig. 1

2. Use the hooks to disengage the catches inside of each air vent (Fig. 2)



Fig. 2

3. Use a panel removal tool to partially pull out and remove the air vent panel and then disconnect the connections to the hazard warning light (Fig. 3)



Fig. 3

4. Fully remove the air vent panel by hand, pulling the panel forward out of the dashboard (Fig. 4)



Fig. 4

INSTALLATION GUIDE

5. Use a panel removal tool to loosen the lower fascia panel with pocket and then fully remove the panel by hand (*Fig. 5*)



Fig. 5

6. Use a screwdriver to remove the four (4) Torx screws at the four located circled (*Fig. 6*)



Fig. 6

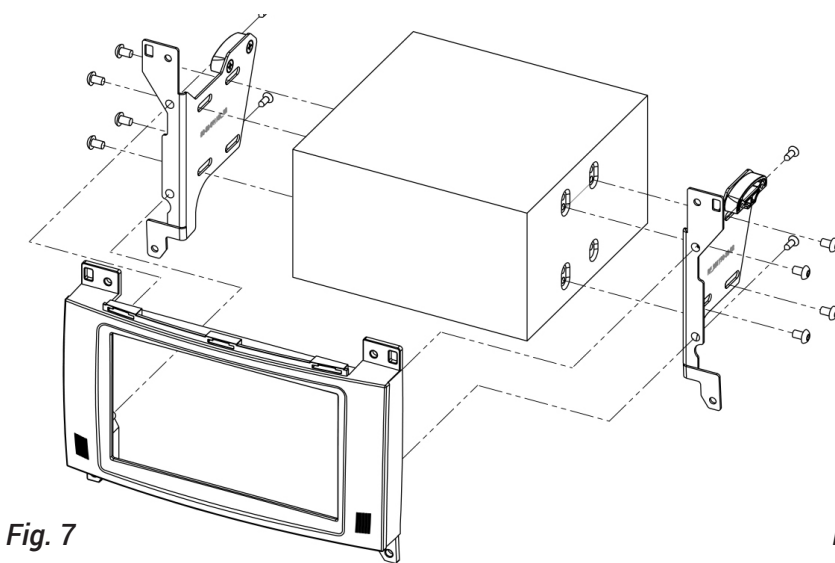

Fig. 7

7. Mount the two brackets to the sides of the after-market stereo and screw into place. Then mount the double DIN fascia panel onto the stereo/bracket assembly and screw to secure. (*Fig. 7*)

8. Make all wiring connections to the vehicle and push the double DIN stereo and fascia assembly into the dashboard until secure (*Fig. 8*)

Reinstall all other components in the reverse order of disassembly to complete the installation.



Fig. 8

NOTES
